

Owners & Installation

Manual

LISTINGS AND CODE APPROVALS

These gas appliances have been tested in accordance with AG 103, NZS 5262 and have been certified by the Australian Gas Association for installation and operation as described in these Installation and Operating Instructions.

Your unit should be serviced annually by an authorised service person.

Masport®

Freestanding Gas Stove

Models: F38-NG1
F38-LPG1



PLEASE KEEP THESE INSTRUCTIONS FOR FUTURE REFERENCE

WARNING:

Improper installation, adjustment, alteration, service or maintenance can cause injury or property damage. Refer to this manual. For assistance or additional information consult an authorized installer, service agency or the gas supplier.

FOR YOUR SAFETY

Do not store or use gasoline or other flammable vapours and liquids in the vicinity of this or any other appliance.

Installation and service must be performed by an authorized installer, service agency or the gas supplier.

FOR YOUR SAFETY

What to do if you smell gas:

- Do not try to light any appliance
- Do not touch any electrical switch: do not use any phone in your building.
- Immediately call your gas supplier from a neighbour's phone. Follow the gas supplier's instructions.
- If you cannot reach your gas supplier, call the fire department.

Australia
P.O. Box 533
Braeside, Victoria 3195

New Zealand
1-37 Mt Wellington Hwy. Panmure,
P.O. Box 14349
Auckland 6.

To the New Owner:

Congratulations! You are the owner of a state-of-the-art Gas Stove by FIREPLACE PRODUCTS INTERNATIONAL LTD. The Masport Gas Series of hand crafted appliances has been designed to provide you with all the warmth and charm of a woodstove, at the flick of a switch.

The models F38-NG1, and F38-LPG1 of this series has been approved by AGA for both safety and efficiency. As it also bears our own mark, it promises to provide you with economy, comfort and security for many trouble free years to follow. Please take a moment now to acquaint yourself with these instructions and the many features of your Masport Gas Stove.

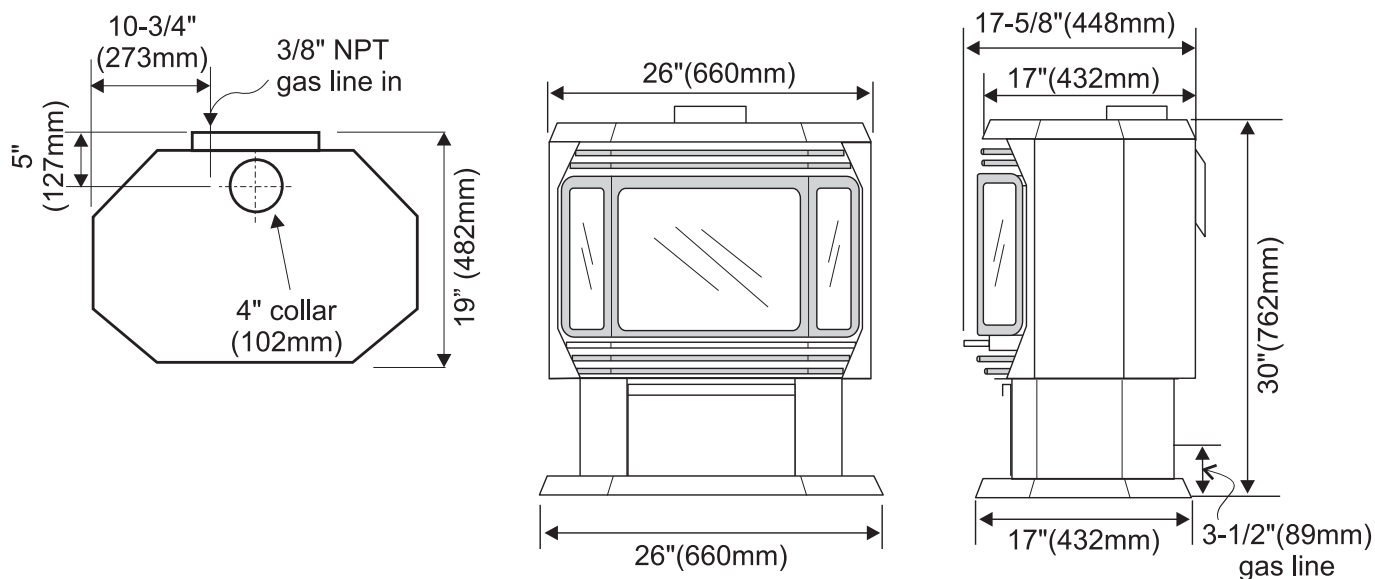

F38-NG1 & F38-LPG1

TABLE OF CONTENTS

| | Page | | Page |
|----------------------------------|------|---|------|
| Safety Label | | Operating Instructions | |
| Specifications | 2 | Operating Instructions | 14 |
| Safety Label | 4 | Lighting Instructions | 14 |
| Installation | | Shutdown Instructions | 14 |
| General Information | 5 | First Fire | 14 |
| Before you start | 5 | Convection Fan Operation | 14 |
| General Safety Information | 5 | Flame Height Adjustment | 14 |
| Installation Checklist | 6 | Copy of Lighting Plate Instructions | 15 |
| Clearances to Combustibles | 6 | Pilot Adjustment | 16 |
| Draft diverter | 6 | Normal Operating Sounds of Gas Appliances | 16 |
| Flueing | 6 | Maintenance | |
| - Flueing Requirements | 6 | Maintenance Instructions | 17 |
| Gas Connection | 7 | Log Replacement | 17 |
| Gas Pressure Test | 7 | Gold Plated Doors | 17 |
| System Data | 7 | Door and Glass Gasket | 17 |
| Conversion from NG to LPG | 8 | Glass Replacement | 17 |
| Aeration Adjustment | 9 | Fan Maintenance | 18 |
| Log Installation | 9 | Removing Valve | 19 |
| Front Door Installation | 11 | DC Spark Box Battery Replacement | 19 |
| Test for Flue Spillage | 11 | Parts List | 20 |
| Optional Wall Thermostat | 12 | Warranty | |
| Optional Remote Control | 12 | Warranty | 23 |
| Final Check | 12 | | |
| Wiring Diagram | 13 | | |

SAFETY LABEL

This is a copy of the label that accompanies each Freestanding Gas Stove. We have printed a copy of the contents here for your review. The safety label is located on the inside of the drop down pedestal door.

NOTE: Masport units are constantly being improved. Check the label on the unit and if there is a difference, the label on the unit is the correct one.

Masport Gas Fireplace

| | | | |
|--------------------------------------|--|-----------------------|--|
| Model | <input type="radio"/> | <input type="radio"/> | Distributed by: Masport Pty. Ltd. PO Box 533 Braeside, Victoria. 3195 Masport Ltd. 1-37 Mt. Wellington H/Way Auckland 6 New Zealand To be installed by an authorised person in accordance with installation instructions provided with the appliance |
| Gas Type | NG | LPG | |
| Model | F38-2 NG | F38-2 LPG | Serial Number 250 |
| Gas Consumption | 38mj. | 31mj. | |
| Manifold Pressure | .87kPa | 2.65kPa | |
| Injector Size | 1x#33 2.87mm | 1x#52 1.61mm | |
| AGA Approval number to Code AG103 | 6231 | 6231 | |
| Electrical: 240VAC 50Hz 1.0 amp max. |  | | |

918-188a 11/03



DO NOT OPERATE THIS APPLIANCE BEFORE READING THE INSTRUCTIONS BOOKLET.

DO NOT PLACE ARTICLES ON OR AGAINST THIS APPLIANCE

DO NOT STORE CHEMICALS OR FLAMMABLE MATERIALS, OR SPRAY AEROSOLS NEAR THIS APPLIANCE.

DO NOT OPERATE WITH PANELS, COVERS OR GUARDS REMOVED FROM THIS APPLIANCE.

DO NOT ENCLOSE THIS APPLIANCE.

908-602

THE GUARD IS FITTED TO THIS APPLIANCE TO REDUCE THE RISK OF FIRE OR INJURY FROM BURNS AND NO PART OF IT SHOULD BE PERMANENTLY REMOVED.

FOR PROTECTION OF YOUNG CHILDREN OR THE INFIRM, A SECONDARY GUARD IS REQUIRED.

(Australia Only)

GENERAL INFORMATION

This installation must conform with local codes or, in the absence of local codes, with AG 601 (Australia) NZS 5261 (New Zealand).



THIS APPLIANCE SHOULD BE INSTALLED, REPAIRED, INSPECTED BEFORE USE AND AT LEAST ANNUALLY BY AN AUTHORISED SERVICE PERSON. MORE FREQUENT CLEANING MAY BE REQUIRED, DUE TO EXCESSIVE LINT FROM CARPETING, ETC. IT IS IMPERATIVE THAT CONTROL COMPARTMENT, BURNERS AND CIRCULATING AIR PASSAGEWAYS OF THE APPLIANCE BE KEPT CLEAN.



DUE TO HIGH TEMPERATURES, THE APPLIANCE SHOULD BE LOCATED OUT OF TRAFFIC AND AWAY FROM FURNITURE AND DRAPERIES.



THIS APPLIANCE CAN ONLY BE FLUED IN ACCORDANCE WITH AG 601 OR LOCAL CODES.



FAILURE TO INSTALL THIS APPLIANCE CORRECTLY MAY CAUSE A SERIOUS

HOUSE FIRE.

Provide adequate clearances for servicing, proper operation and around the air openings into the combustion chamber. Adequate combustion and ventilation air must also be provided.

The appliance must be installed on a flat, solid, continuous surface (i.e. wood, metal, concrete). This may be the floor, or it can be raised up on a platform to enhance its visual impact.

The Masport Freestanding Gas Heater can be installed in a wide variety of ways and will fit nearly any room layout. It may be installed in a recessed position, framed out into the room, or across a corner.

We recommend that you plan your installation on paper using exact measurements for clearances and floor protection before actually installing this appliance. If an existing chimney is not utilised, position the appliance to allow free passage of factory-built listed chimney through the ceiling and roof.

IMPORTANT:

The F38-1 Freestanding Gas Stove must be installed in accordance with these instructions. Carefully read all the instructions in this manual first. Consult the "authority having jurisdiction" to determine the need for a permit prior to starting the installation.

BEFORE YOU START

INSTALLATION AND REPAIR SHOULD BE DONE BY AN AUTHORISED SERVICE PERSON. THE APPLIANCE SHOULD BE INSPECTED BEFORE USE AND AT LEAST ANNUALLY BY AN AUTHORISED SERVICE PERSON. MORE FREQUENT CLEANING MAY BE REQUIRED DUE TO EXCESSIVE LINT FROM CARPETING, BEDDING MATERIAL, ETC. IT IS IMPERATIVE THAT CONTROL COMPARTMENTS, BURNERS AND CIRCULATING AIR PASSAGEWAYS OF THE APPLIANCE BE KEPT CLEAN.

DUE TO HIGH TEMPERATURES, THE APPLIANCE SHOULD BE LOCATED OUT OF TRAFFIC AND AWAY FROM FURNITURE AND DRAPERIES.

WARNING: FAILURE TO INSTALL THIS APPLIANCE CORRECTLY MAY CAUSE A SERIOUS HOUSE FIRE AND WILL VOID YOUR WARRANTY.

CHILDREN AND ADULTS SHOULD BE ALERTED TO THE HAZARDS OF HIGH SURFACE TEMPERATURES, ESPECIALLY THE FIREPLACE GLASS, AND SHOULD STAY AWAY TO AVOID BURNS OR CLOTHING IGNITION.

YOUNG CHILDREN SHOULD BE CAREFULLY SUPERVISED WHEN THEY ARE IN THE SAME ROOM AS THE APPLIANCE.

CLOTHING OR OTHER FLAMMABLE MATERIAL SHOULD NOT BE PLACED ON OR NEAR THE APPLIANCE.

GENERAL SAFETY INFORMATION

- 1) The appliance shall be installed in accordance with the manufacturer's installation instructions, local gas fitting regulations, municipal building codes, water supply regulations, electrical wiring regulations, with AG 601 (AGA gas installation code) NZS 5261 (New Zealand)
- 2) Installation and repair should be done **ONLY** by an authorised person.
- 3) See general construction and assembly instructions. **The appliance should be inspected before use and at least annually by an authorised service person. More frequent cleaning may be required due to excessive lint from carpeting, bedding material, etc. It is imperative that control compartments, burners and circulating air passageways of the appliance be kept clean and free from excessive lint from carpeting.**
- 4) This appliance must be connected to a flue and terminate to the outside of the building envelope. Never flue to another room.
- 5) Inspect the flueing system annually for blockage and any signs of deterioration.
- 6) Any safety glass removed for servicing must be replaced prior to operating the appliance.
- 7) To prevent injury, do not allow anyone who is unfamiliar with the operation to use the fireplace.
- 8) Wear gloves and safety glasses for protection while doing required maintenance.
- 9) Under no circumstances should this appliance be modified. Parts that have to be removed for servicing should be replaced prior to operating this appliance.
- 10) Installation and any repairs to this appliance should be done by an authorised service person. An authorised service person should be called to inspect this appliance annually. Make it a practice to have all of your gas appliances checked annually.
- 11) Do not strike the glass door.
- 12) Under no circumstances should any solid fuels (wood, paper, cardboard, coal, etc.) be used in this appliance.
- 13) The appliance area must be kept clear and free of combustible materials, (gases and other flammable vapours and liquids).

INSTALLATION

- 14) This unit can be installed on a solid combustible surface like a wood floor as well as on carpeting.

INSTALLATION CHECKLIST

- 1) Check Clearances to Combustibles, page 6.
- 2) Install flueing, page 6.
- 3) Make gas connections, page 7. Test the pilot. Must be as per diagram, page 16.
- 4) If necessary, convert NG to LPG on page 8.
- 5) Test Gas Pressure, page 7.
- 6) Install log set where indicated on page 9.
- 7) Install Front Door, page 11.
- 8) Test for flue spillage (draft test), page 11.
- 9) Install optional Remote Control, or Wall Thermostat, page 12.
- 10) Final check, page 12.

Before leaving this unit with the customer, the installer must ensure that the appliance is firing correctly and operation fully explained to customer.

This includes:

- 1) Clocking the appliance to ensure the correct firing rate (rate noted on label) after burning appliance for 15 minutes.
- 2) If required, adjusting the primary air to ensure that the flame does not carbon. First allow the unit to burn for 15-20 min. to stabilize.

CAUTION: Any alteration to the product that causes sooting or carboning or that results in damage is not the responsibility of the manufacturer.

CLEARANCES TO COMBUSTIBLES

The clearances listed below are MINIMUM distances. Measure the clearance to both the appliance and the chimney connector. **(The farthest distance is correct if the two clearances do not coincide.)** For example, if the appliance is set as indicated in one of the figures but the connector is too close, move the stove until the correct clearance to the connector is obtained.

This unit can be installed on a solid combustible surface like a wood floor. This unit can also be installed directly on carpeting or vinyl when the bottom pedestal cover plate (provided with unit) is installed.

This appliance may be installed only with the clearances as shown in the situations pictured. Do not combine clearances from one type of installation with another in order to achieve closer clearances.

Use the minimum clearances shown in the diagrams below for all installations.

F38-NG1 & F38-LPG1 Clearances

| | |
|---------------------|-----------------|
| A Side Wall to Unit | 7-1/2" / 190 mm |
| B Back Wall to Unit | 6" / 155 mm |
| E Side Wall to Unit | 2" / 50 mm |

F38-NG1 & F38-LPG1 Reference Dimensions

| | |
|--------------------------------|------------------|
| C Back Wall to Flue Centerline | 10-3/4" / 273 mm |
| D Side Wall to Flue Centerline | 20-1/2" / 520 mm |
| F Side Wall to Flue Centerline | 11" / 280 mm |

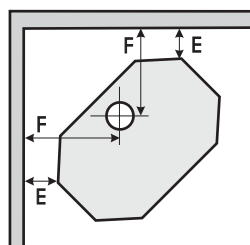
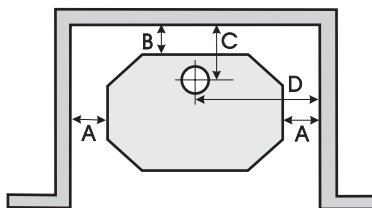

Minimum ceiling height is 36" / 914 mm from top of unit.

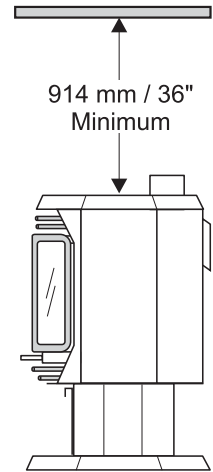

If further reduced clearances are needed, obtain requirements for construction of a protected wall from your local building authorities and their allowable reductions of the listed clearances.

DRAFT DIVERTER

This heater has a draft diverter built in. It must not be altered, obstructed, or blocked in any way, and the unit must be installed so that the draft diverter is in the same atmospheric pressure zone as the combustion air inlet to the burner. This heater must be properly connected to a flueing system. This heater is equipped with a flue safety shutoff system.

WARNING: Operation of this heater when not connected to a properly installed and maintained flueing system or tampering with the flue safety shutoff system can result in carbon monoxide (CO) poisoning and possible death.

FLUEING

This heater is a flued appliance and must be connected to a chimney/flue in accordance with the installation codes.

Note: The rear pedestal cover plate must always be fitted for safety. Electrical connections inside.

For your safety this heater is equipped with a flue safety switch designed to sense incorrect flueing and react by shutting down the gas supply. This thermally actuated switch is located within the draft diverter and will detect either a blocked chimney or backdraft condition where the chimney flow has reversed. If this switch shuts the unit down, it indicates a drafting problem that must be identified and rectified without delay - the thermally activated switch must **never** be bypassed or disconnected as a hazardous or deadly condition can result.

Flueing Requirements

A 100 mm diameter flue is required. For cosmetic or aesthetic purposes 6" outer flue can be used

as long as an approved inner flue is installed. Fasten but do not penetrate the inner sleeve of the flue when tightening the screw.

The minimum flue required is 3.3m from floor level.

Follow all flueing manufacturer's requirements and local building codes or AG 601.

GAS CONNECTION

The gas line should be rigid pipe. Copper may also be used if approved by AG 601.

The gas connection at the valve is 1/2 male. For minimum and maximum supply pressure see the System Data Table.

GAS PIPE PRESSURE TESTING

The appliance must be isolated from the gas supply piping system by closing its individual manual shut-off valve during any pressure testing of the gas supply piping system at test pressures equal to or less than 1/2 psig. (3.45 kPa). Disconnect piping from valve at pressures over 3.45 kPa (14" w.c.).

The manifold pressure is controlled by a regulator built into the gas control, and should be checked at the pressure test point.

Note: *To properly check gas pressure, both inlet and manifold pressures should be checked using the valve pressure ports on the valve.*

- 1) Make sure the valve is in the "OFF" position.
- 2) Loosen the "IN" (# 7) and/or "OUT" (# 6) pressure tap(s), turning counterclockwise with a 1/8" wide flat screwdriver.
- 3) Attach manometer to "IN" and/or "OUT" pressure tap(s) using a 5/16" ID hose.
- 4) Light the pilot and turn the valve to "ON" position.
- 5) The pressure check should be carried out with the unit burning and the setting should be within the limits specified on the safety label.
- 6) When finished reading manometer, turn off the gas valve, disconnect the hose and tighten the screw (clockwise) with a 1/8" flat screwdriver. *Screw should be snug, but do not over tighten.*

S.I.T. Valve Description

- 1) Gas cock knob
- 2) Manual high/low adjustment
- 3) Pilot Adjustment
- 4) Thermocouple Connection
- 5) Main Operator
- 6) Outlet Pressure Tap
- 7) Inlet Pressure Tap
- 8) Pilot Outlet
- 9) Main Gas Outlet
- 10) Flange Securing Screw Holes
- 11) Alternative TC Connection Point
- 12) Thermoelectric Unit
- 13) Additional Valve Mounting Hole

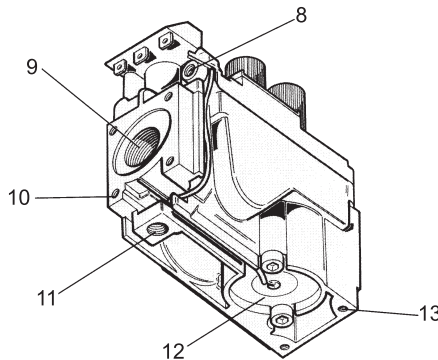
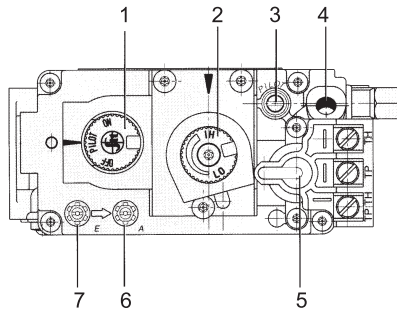

System Data F38-1

F38-NG1: For 0 to 610 meters altitude
F38-LPG1: For 0 to 610 meters altitude

| | | |
|-----------------------------|-----|-----|
| Burner Inlet Orifice Sizes: | | |
| Burner | NG | LPG |
| | #33 | #52 |

| | |
|-------------------|-------|
| Max. Input | |
| NG | 38 mj |
| LPG | 31 mj |

| | |
|-------------------|---------|
| Min. Input | |
| NG | 24.1 mj |
| LPG | 24.5 mj |

| | |
|------------------------|----------|
| Supply Pressure | |
| NG | 1.74 kPa |
| LPG | 2.99 kPa |

| | |
|--------------------------|----------|
| Manifold Pressure | |
| NG | 0.87 kPa |
| LPG | 2.65 kPa |

Electrical: 240 V. 50Hz.
Circulation: High/Off/LO speed fan, 150/89 CFM.
Log Set: Ceramic fiber, 7 per set.

| | |
|-------------------------|-----------|
| Aeration Setting | |
| NG | Full Open |
| LPG | 6.4 mm |

| | |
|--------------------------------|-----------|
| Flue Restrictor Setting | |
| NG | Full Open |
| LPG | Full Open |

INSTALLATION

CONVERSION FROM NG TO LPG

**THIS CONVERSION MUST BE DONE BY A QUALIFIED GAS FITTER
IF IN DOUBT DO NOT DO THIS CONVERSION !!**

Conversion Kit 680-969 Contains:

| Qty. | Part # | Description |
|------|---------|---|
| 1 | 910-018 | SIT Conversion Kit- 50% Turndown LPG |
| 1 | 910-037 | LPG Injector (Pilot Orifice) |
| 1 | 904-390 | Burner Orifice #52 |
| 1 | 908-528 | Red "LPG" label |
| 1 | 908-255 | Label "Converted to LPG" |
| 1 | 918-032 | Instruction Sheet |

- 1) Shut off the gas supply.
- 2) Open the front door and carefully remove the logs and lava rock.
- 3) Remove burner. See diagram below.

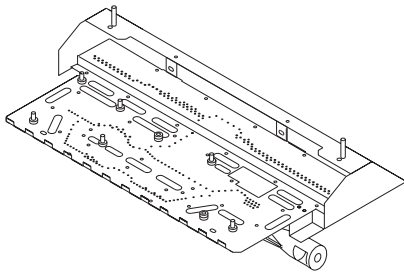

Note: Use a magnetic type screwdriver if possible.

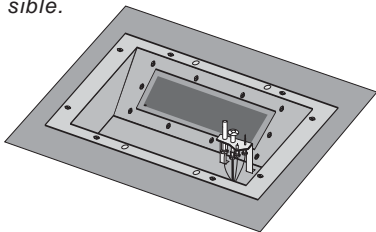

Pilot assembly is now accessible for steps 4) to 9).

- 4) Remove and discard the 3 pressure regulator mounting screws (A), pressure regulator tower (B) and diaphragm (C).
- 5) Insure that the rubber gasket (D) is properly positioned and install the new HI/LO pressure regulator assembly to the valve using the new screws (E) supplied with the kit. Tighten screws securely.
- 6) Pull off the pilot cap to expose the pilot orifice.



- 7) Unscrew the pilot orifice with the allen key and replace with the LPG pilot orifice in the kit.



- 8) Remove burner orifice with a 1/2" wrench and discard. Use a wrench to hold on to the elbow behind the orifice.

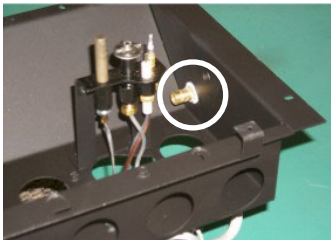

Burner Orifice

- 9) Reinstall new burner orifice LPG stamped #52 and tighten.
- 10) Reverse steps 3) to 2).
- 11) Attach the Conversion label "This unit has been converted to LPG" on top of the Serial # decal.
- 12) Replace yellow "NG" label with red "LPG" label
- 13) Check for gas leaks.
- 14) Check inlet and outlet pressures.
- 15) Check operation of flame control.
- 16) Check for proper flame appearance and glow on logs.

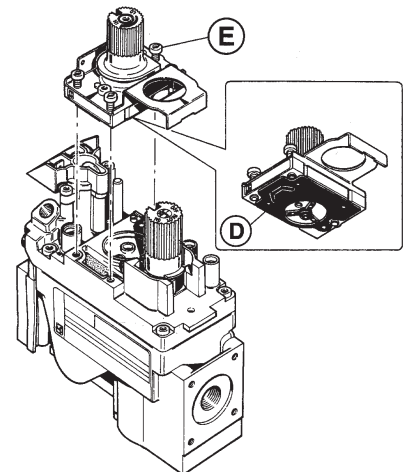
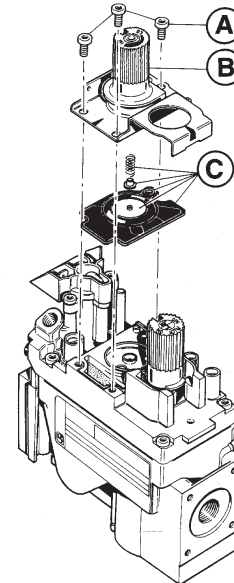

Installer Notice:
These instructions must be left with the appliance.

AERATION ADJUSTMENT

The burner aeration is factory set but may need adjusting due to either the local gas supply or altitude.

F38-1 with 38 mj

F38-NG1 NG: Full open
F38-LPG1 LPG: 6.4 mm open

Caution: Carbon will be produced if the air shutter is closed too much.

Note: Any damage due to carboning resulting from improperly setting the aeration controls is NOT covered under warranty.

LOG SET INSTALLATION

Read the instructions below carefully and refer to the diagrams. If logs are broken do not use the unit until they are replaced. Broken logs can interfere with the pilot operation.

The gas log kit contains the following:

- | | | | |
|----|-------|------------------|---------|
| a) | 02-65 | Rear Log | 902-267 |
| b) | 02-56 | Middle Left Log | 902-230 |
| c) | 02-44 | Front Left Log | 902-228 |
| d) | 02-46 | Left Top Log | 902-231 |
| e) | 02-45 | Front Right Log | 902-229 |
| f) | 02-47 | Center Log | 902-232 |
| g) | 02-48 | Middle Right Log | 902-226 |
| h) | | Embers | 902-151 |
| i) | | Lava | 902-154 |

Note: Install Optional Brick Panels prior to installing logs.

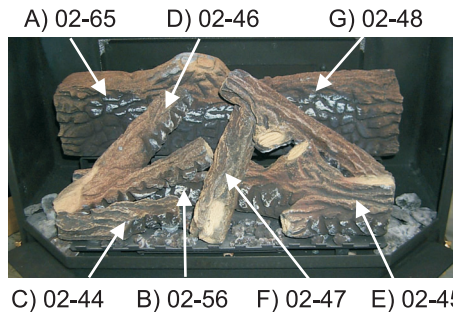

The "02" refer numbers (i.e. 02-65) are molded into the rear of each log.

- Carefully remove the logs from the box and unwrap them. The logs are fragile, handle with care - **do not force into position.**
- Sprinkle the embers on the left and right sides of the firebox base.



- Place Rear Log A)02-65 on the two pins on the rear log support.

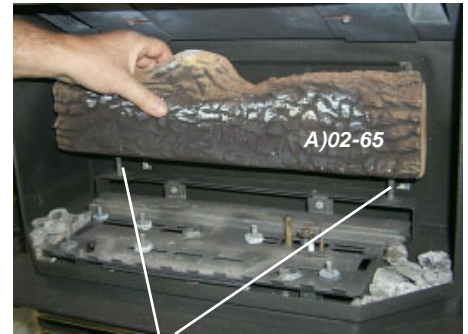

Pins on Rear Log Support

- Place the Middle Left Log B)02-56 on the two pins as shown.



- Place Front Left Log C)02-44 onto the 2 front pins as shown.



INSTALLATION

- 6) Place the Left Top Log D)02-46 on the pin on Log B)02-56 and on top of the cutout on Log A)02-65.

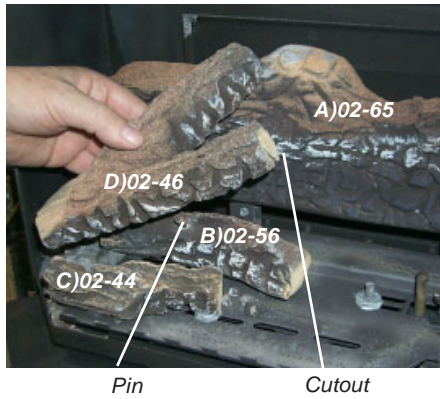

- 9) Place the notch in Center Log F)02-47 over Log E)02-45 and across the cutout on Log A)02-65.

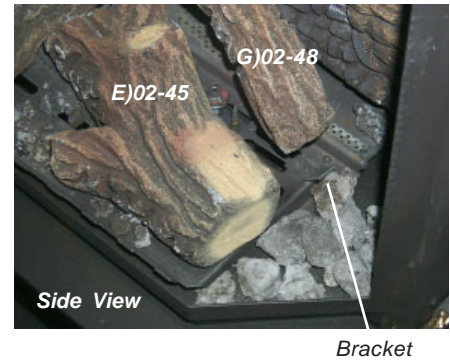
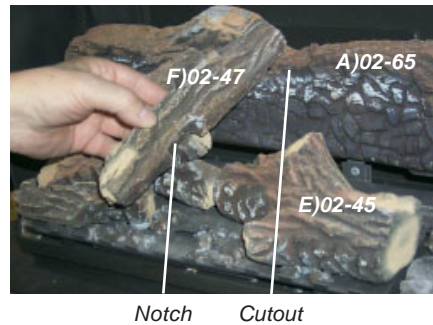

The bottom right edge of Log G)02-48 must sit snugly against the bracket

- 7) Place Front Right Log E)02-45 on the two pins as shown.



- 10) Position notch in Front Right Log G)02-48 on Log F)02-47 and push the bottom right edge against the bracket on the burner tray.

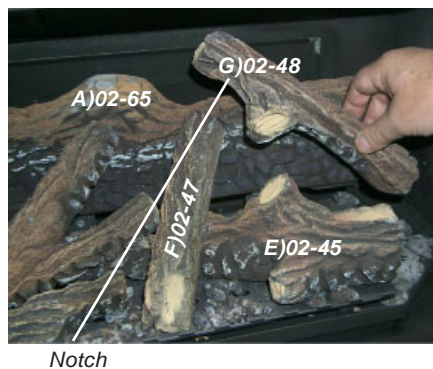

- 11) Test fire to ensure proper light off (make sure flame flows smoothly from one end of burner to the other. If there is any flame hesitation, check that area for any blockage of the burner port.

- 8) Place the lava rock in the area between the left and right logs, leaving a space in the middle for log (F) 02-47.

Ensure that the lava rocks are **not placed directly over the burner ports.**

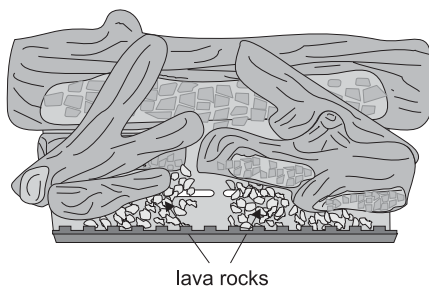

FRONT DOOR INSTALLATION

- 1) Open the two side panels.
- 2) Slide the door onto the two hinge pins making sure the two pieces are flush together. See diagram 1.

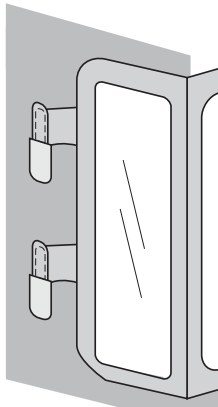

Diagram 1

- 3) Close the door. The latch plate must be centered around the alignment pin. See diagram 2. If the latch plate interferes with the corner of the stove you may want to angle the plate slightly so the door closes easier.

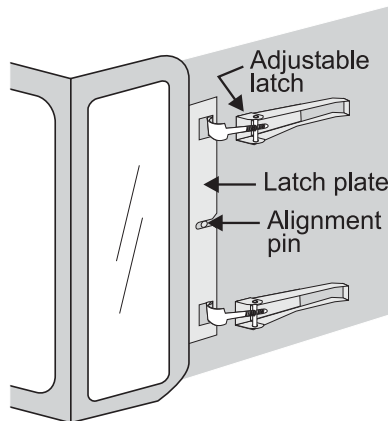

Diagram 2

- 4) The latches should already be at the proper setting. If they are too hard or too easy to close, you may want to adjust them by loosening the latch catch. See diagram 3.
- 5) Remove the blue plastic protective coating from the glass.

- 6) Test the seal around the door by placing a piece of paper between the unit and the door, close the door and try to pull the paper out. If it slips out easily, then the door is not properly sealed. Tighten or loosen the latch. See diagram 3.

Note: *The door latch may require adjustment as the door gasket material compresses after a few fires and after glass replacement. Turn the latch catch inward or outward to loosen or tighten.*

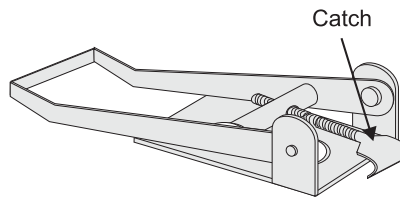
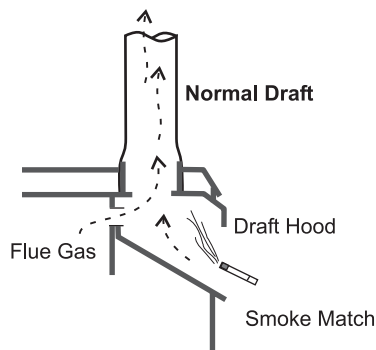

Diagram 3

TEST FOR FLUE SPILLAGE

A "spillage" test must be made before the installed unit is left with the customer. Follow the procedure below:

- 1) Start all exhaust fans in the home and any other gas appliances. Then close all doors and windows.
- 2) Light the unit and set controls to maximum.
- 3) After five minutes, test that there is a "pull" on the flue by placing a smoke match, cigarette or similar device which gives off smoke, on the edge of the draft diverter. See diagrams.



The smoke should be drawn into the draft diverter. If the smoke is not drawn into the draft diverter, turn the unit off and check for the cause of lack of draft.

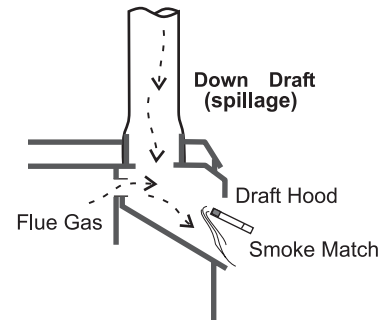

Note: If the flue is blocked or has a strong reverse flow, the thermally actuated safety switch mounted in the draft diverter will automatically shut off the gas supply within about 10 minutes. If the heater turns off because of this during the spillage test, check for the cause of the lack of draft.

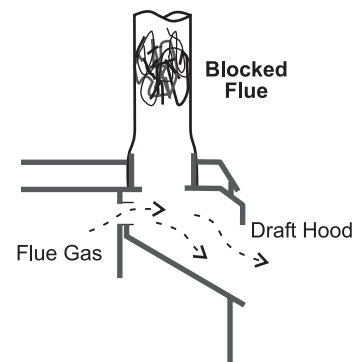

The thermally activated safety switch must be manually reset before first startup.

INSTALLATION

OPTIONAL WALL THERMOSTAT

A wall thermostat may be installed if desired. Connect the wires as per the wiring diagrams. Note that the wires are connected to the "TH" on the gas valve. Use table below to determine the maximum wire length:

Note: Preferable if the thermostat is installed on an interior wall.

Masport offers an optional programmable thermostat but any 250-750 millivolt rated non-anticipator type thermostat that is CSA, ULC or UL approved may be used.

CAUTION
Do not connect the millivolt wall thermostat wires to the 240 V wires.

Thermostat Wire Table

| Recommended Maximum Lead Length (Two-Wire) When Using Wall Thermostat (CP-2 System) | |
|---|-------------|
| Wire Size | Max. Length |
| 14 GA. | 15.24 m |
| 16 GA. | 9.75 m |
| 18 GA. | 6.10 m |
| 20 GA. | 3.66 m |
| 22 GA. | 2.71 m |

OPTIONAL REMOTE CONTROL

Use the Masport Remote Control Kit approved for this unit. Use of other systems may void your warranty.

The remote control kit comes with a hand held transmitter, a receiver and a wall mounting plate.

- 1) Choose a convenient location on the wall to install the receiver and the receptacle box (protection from extreme heat is very important). Run wires from the fireplace to that location, use Thermostat Wire Table.
- 2) Connect the wires as per the wiring diagram above.

CAUTION
Do not connect the millivolt remote control wires to the 240V wires.

- 3) Install 3 AAA alkaline batteries in transmitter and 4 AA alkaline batteries in the receiver. Install the receiver and its cover in the wall. Switch the remote receiver to "remote" mode. The remote control is now ready for operation.

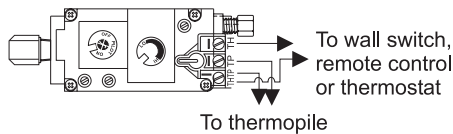

FINAL CHECK

Before leaving this unit with the customer, the installer must ensure that the appliance is firing correctly. This includes:

- 1) Locking the appliance to ensure the correct firing rate (rate noted on label) at 15 minutes.
- 2) If required, adjusting the primary air to ensure that the flame does not carbon. First allow the unit to burn for 15 min. to stabilize.
- 3) Check for proper draft.

CAUTION

Any alteration to the product that causes sooting or carboning that results in damage to the exterior facia is not the responsibility of the manufacturer.

WIRING

No electrical power supply is required for the gas control to operate. However, a 240V A.C. power supply is needed for the fan/blower operation.

Caution: Ensure that the wires do not touch any hot surfaces and are away from sharp edges.

WARNING: Electrical Grounding Instructions

This appliance is equipped with a three pronged (grounding) plug for your protection against shock hazard and should be plugged directly into a properly grounded three-prong receptacle. Do not cut or remove the grounding prong from this plug.

CAUTION:

Label all wires prior to disconnection when servicing controls. Wiring errors can cause improper and dangerous operation.

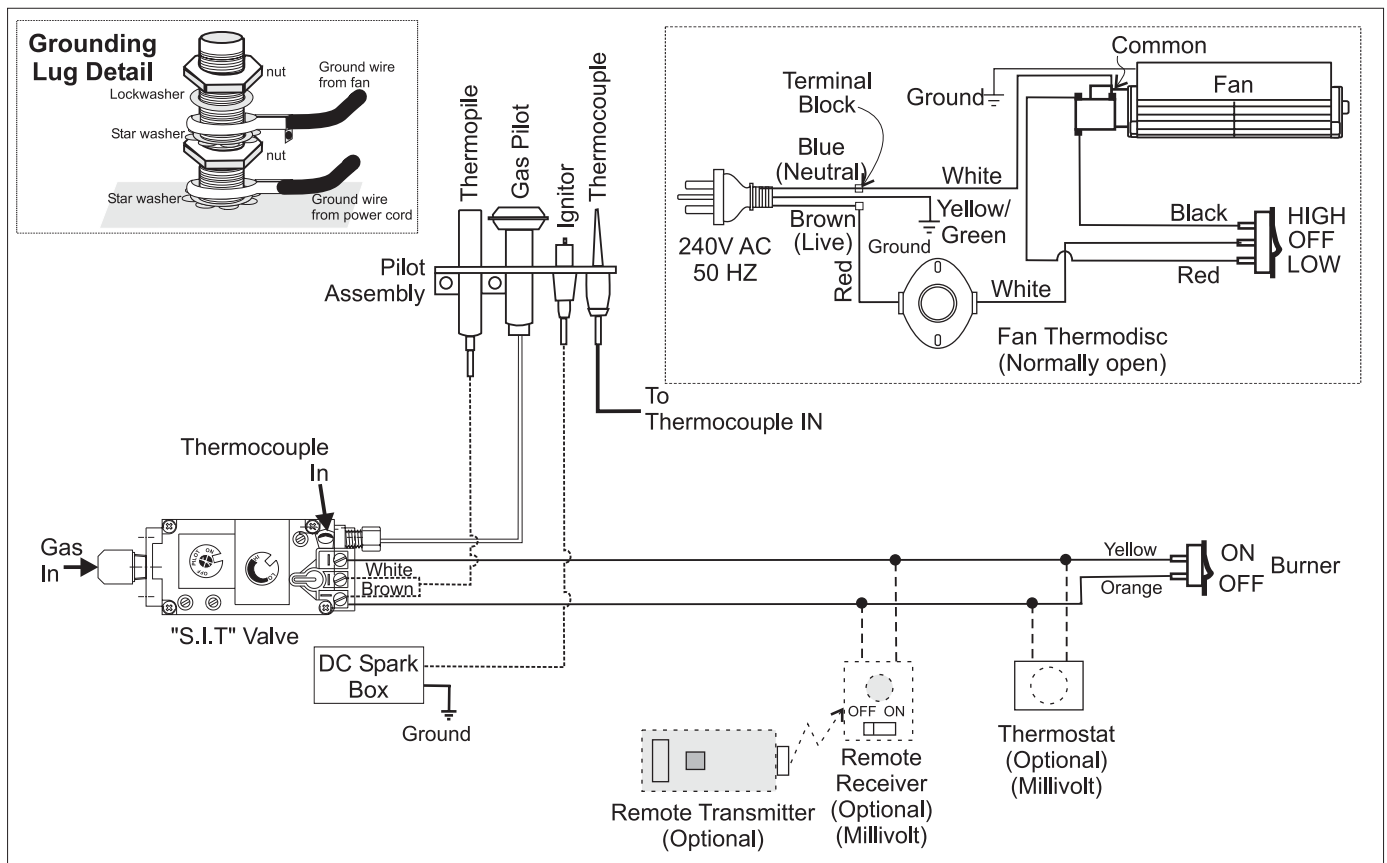

OPERATING INSTRUCTIONS

OPERATING INSTRUCTIONS

Before operating this appliance, proceed through the following check list.

- 1) Read and understand these Instructions before operating this appliance.
- 2) Check to see that all wiring is correct and enclosed to prevent possible shock.
- 3) Check to ensure there are no gas leaks.
- 4) Make sure the three pieces of door glass are properly positioned. Never operate the appliance with any of the glass removed or with the door open.
- 5) Verify that all flueing and the cap is unobstructed.
- 6) Verify log placement. If the pilot cannot be seen when lighting the unit - the logs or the embers have been incorrectly positioned.
- 7) The unit should never be turned off and on without a minimum of a 60 second wait.

LIGHTING INSTRUCTIONS

- 1) Push in gas control knob slightly and turn to "PILOT" position.
- 2) Push in control knob all the way and hold in until the pilot lights up. Continue to hold the control knob in for about 20 seconds after the pilot is lit. Release knob.
- 3) Push in gas control knob slightly and turn to "ON" position.
- 4) Turn ON the flame switch.

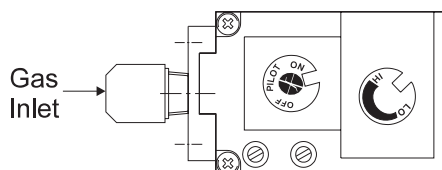

SHUTDOWN INSTRUCTIONS

- 1) Turn OFF the flame switch.
- 2) Push in gas control knob slightly and turn to "OFF" position.

FIRST FIRE

The **FIRST FIRE** in your heater is part of the paint curing process. To ensure that the paint is properly cured, it is recommended that you burn your fireplace for at least four (4) hours the first time you use it with the fan on.

When first operated, the unit will release an odour caused by the curing of the paint and the burning off of any oils remaining from manufacturing. Smoke detectors in the house may go off at this time. Open a few windows to ventilate the room for a couple of hours. The glass may require cleaning.

DO NOT ATTEMPT TO CLEAN THE GLASS WHILE IT IS STILL *HOT!*

Note: When the glass is cold and the appliance is lit, it may cause condensation and fog the glass. This condensation is normal and will disappear in a few minutes as the glass heats up.

DO NOT BURN THE APPLIANCE WITHOUT THE GLASS FRONT IN PLACE.

DO NOT BURN THE APPLIANCE WITHOUT THE GLASS FRONT IN PLACE.

AUTOMATIC CONVECTION FAN OPERATION

Set the fan speed on control panel at the top rear of the unit to adjust to the desired speed. The fan will turn on as the stove comes up to operating temperature. After the unit has been turned off and the unit cooled to below a useful heat output range the fan will shut off automatically.

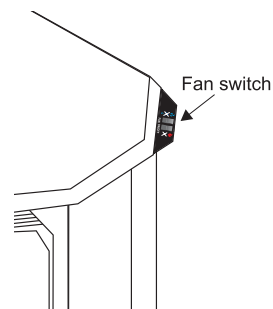

ADJUSTING FLAME HEIGHT

Your heater has an adjustable flame to tailor the look and heat output to your specific needs. It is adjusted by turning the flame adjustment dial on the gas control valve.

Turn clockwise to adjust the flame higher, counterclockwise for a lower flame.

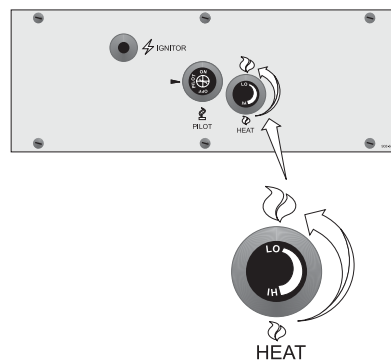

WARNING
DO NOT SPRAY AEROSOLS IN THE VICINITY OF THIS APPLIANCE WHILE IN OPERATION

OPERATING INSTRUCTIONS

COPY OF THE LIGHTING PLATE INSTRUCTIONS

FOR YOUR SAFETY READ BEFORE LIGHTING

This appliance must be installed in accordance with local codes, if any; if not, follow the current CAN1-B149/ANSI Z 223.1 (Australia: AG601, New Zealand: NZS 5261)

WARNING: If you do not follow these instructions exactly, a fire or explosion may result causing property damage, personal injury or loss of life. Improper installation, adjustment, alteration, service or maintenance can cause injury or property damage. Refer to the owner's information manual provided with this appliance. For assistance or additional information consult a qualified installer, service agency or gas supplier.

A) This appliance has a pilot which must be lighted by hand, following the instructions below exactly.

B) **BEFORE LIGHTING** smell all around the appliance area for gas. Be sure to smell next to the floor because some gas is heavier than air and will settle on the floor.

WHAT TO DO IF YOU SMELL GAS

- Do not try to light any appliance
- Do not touch any electric switch, do not use any phone in your building
- Immediately call your gas supplier from a neighbors phone. Follow the gas supplier's instructions.
- If you cannot reach your gas supplier, call the fire department.

C) Use only your hand to push in or turn the gas control knob. Never use tools. If the knob will not push in or turn by hand, don't try to repair it, call

a qualified service technician. Force or attempted repair may result in a fire or explosion.

D) Do not use this appliance if any part has been under water. Immediately call a qualified service technician to inspect the appliance and to replace any part of the control system and any gas control which has been under water.

This appliance needs fresh air for safe operation and must be installed so there are provisions for adequate combustion and ventilation air.

CAUTION: Hot while in operation. Do not touch. Severe Burns may result. Due to high surface temperatures keep children, clothing and furniture, gasoline and other liquids having flammable vapors away. Keep burner and control compartment clean. See installation and operating instructions accompanying appliance.

LIGHTING INSTRUCTIONS

STOP! Read the safety information above on this label.

- 1) Push in gas control knob slightly and turn to "PILOT" position.
- 2) Push in control knob all the way and hold in until the pilot lights up. Continue to hold the control knob in for about 20 seconds after the pilot is lit. Release knob.
- 3) Push in gas control knob slightly and turn to "ON" position.
- 4) Turn ON the flame switch.

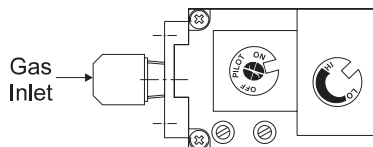

TO TURN OFF GAS APPLIANCE

- 1) Turn OFF the flame switch.
- 2) Push in gas control knob slightly and turn to "OFF" position.

You may shut off the pilot during prolonged non use periods to conserve fuel.

DO NOT REMOVE THIS INSTRUCTION PLATE

918-254

WARNING:
DO NOT SPRAY AEROSOLS IN THE VICINITY OF
THIS APPLIANCE WHILE IN OPERATION.

OPERATING INSTRUCTIONS

PILOT ADJUSTMENT

Periodically check the pilot flames. Correct flame pattern has three strong blue flames: 1 flowing around the thermopile and 1 around the thermocouple, and 1 flowing across the rear of the burner (it does not have to be touching the burner).

Note: *If you have an incorrect flame pattern, contact your Masport dealer for further instructions.*

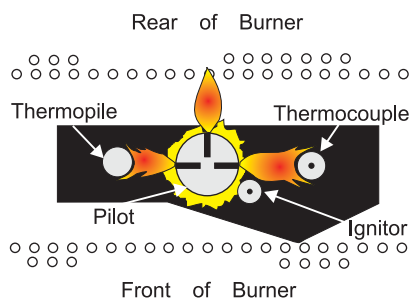

Top View of pilot flame

Incorrect flame pattern will have small, probably yellow flames, not coming into proper contact with the rear of the burner or thermopile.

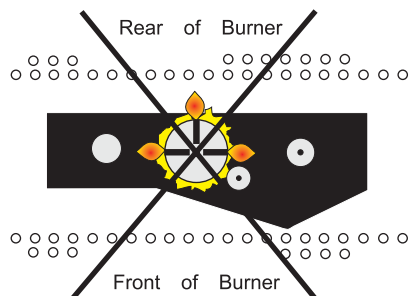

Top View of pilot flame

NORMAL OPERATING SOUNDS OF GAS APPLIANCES

It is possible that you will hear some sounds from your gas appliance. This is perfectly normal due to the fact that there are various gauges and types of steel used within your appliance. Listed below are some examples. All are **normal operating sounds** and should not be considered as defects in your appliance.

Blower:

Masport gas appliances use high tech blowers to push heated air farther into the room. It is not unusual for the fan to make a "whirring" sound when ON. This sound will increase or decrease in volume depending on the speed setting of your fan speed control.

Burner Tray:

The burner tray is positioned directly under the burner tube(s) and logs and is made of a different gauge material from the rest of the firebox and body. Therefore, the varying thicknesses of steel will expand and contract at slightly different rates which can cause "ticking" and "cracking" sounds. You should also be aware that as there are temperature changes within the unit these sounds will likely re-occur. Again, this is normal for steel fireboxes.

Blower Thermodisc:

When this thermally activated switch turns ON it will create a small "clicking" sound. This is the switch contacts closing and is normal.

Pilot Flame:

While the pilot flame is on it can make a very slight "whisper" sound.

Gas Control Valve:

As the gas control valve turns ON and OFF, a dull clicking sound may be audible, this is normal operation of a gas regulator or valve.

Unit Body/Firebox:

Different types and thicknesses of steel will expand and contract at different rates resulting in some "cracking" and "ticking" sounds will be heard throughout the cycling process.

MAINTENANCE INSTRUCTIONS

- 1) Always shut the valve off before cleaning. For relighting, refer to lighting instructions. Keep the burner and control compartment clean by brushing and vacuuming at least once a year. When cleaning the logs, use a soft clean brush as the logs are fragile and easily damaged.
- 2) Clean glass (never when unit is hot), appliance, louvres, and door with a damp cloth. Never use an abrasive cleaner. The gold louvres (and optional gold door) may be scratched if abrasives are used to clean them.

The heater is finished in a heat resistant paint and should only be refinished with heat resistant paint (not with wall paint). Masport uses StoveBright Paint - Metallic Black #6309.

- 3) Make a periodic check of burner for proper position and condition. Visually check the flame of the burner periodically, making sure the flames are steady; not lifting or floating. If there is a problem, call an authorized service person.
 - 4) The appliance and flueing system must be inspected before use, and at least annually, by an authorized field service person, to ensure that the flow of combustion and ventilation air is not obstructed.
- During the annual service call, the burners should be removed from the burner tray and cleaned. Replace the embers - do not block the pilot or burner ports.
- 5) Keep the area near the appliance clear and free from combustible materials, gasoline and other flammable vapours and liquids.

WARNING: CHILDREN AND ADULTS SHOULD BE ALERTED TO THE HAZARDS OF HIGH SURFACE TEMPERATURE AND SHOULD STAY AWAY TO AVOID BURNS OR CLOTHING IGNITION. YOUNG CHILDREN SHOULD BE CAREFULLY SUPERVISED WHEN THEY ARE IN THE SAME ROOM AS THE APPLIANCE.

CAUTION: ANY SAFETY SCREEN OR GUARD REMOVED FOR SERVICING AN APPLIANCE MUST BE REPLACED PRIOR TO OPERATING THE APPLIANCE.

CLOTHING OR OTHER FLAMMABLE MATERIAL SHOULD NOT BE PLACED ON OR NEAR THE APPLIANCE.

DO NOT USE THIS APPLIANCE IF ANY PART HAS BEEN UNDER WATER. IMMEDIATELY CALL AN AUTHORIZED SERVICE TECHNICIAN TO INSPECT THE APPLIANCE AND TO REPLACE ANY PART OF CONTROL SYSTEM AND ANY GAS CONTROL WHICH HAS BEEN UNDER WATER.

- 6) Verify proper operation after servicing.

LOG REPLACEMENT

The unit should never be used with broken logs. Turn off the gas valve and allow the unit to cool before opening door to carefully remove the logs. The pilot light generates enough heat to burn someone. If for any reason a log should need replacement, you must use the proper replacement log. The position of these logs must be as shown in the diagram under Log Installation.

Note: Improper positioning of logs may create carbon build-up and will alter the unit's performance which is not covered under warranty.

DOOR AND GLASS GASKET

If the door gasket requires replacement use 7/8" diameter oval door gasket (Part # 650-920). The glass requires 5/8" flat glass gasket. See your Masport dealer.

GOLD-PLATED DOORS

The 24 carat gold plated finish on the door requires little maintenance, and need only be cleaned with a damp cloth. DO NOT use abrasive materials or chemical cleaners, as they may harm the finish and will void the warranty. Clean any fingerprints off before turning the unit on.

GLASS REPLACEMENT

Your Masport heater is supplied with high temperature, 5mm Neoceram silica coated ceramic glass that will withstand the highest heat that your unit will produce. In the event that you break your glass, purchase your replacement from an authorized Masport dealer only, and follow the step-by-step instructions for replacement.

Removing Glass:

Note: Wearing gloves will protect your hands while handling glass.

- 1) Remove the door from the unit and place on a soft surface to prevent scratching.
- 2) Pull out the door gasket.
- 3) Remove the 24 nuts holding the glass retainers in place. *Do not remove the nuts underneath the retainers.*
- 4) Remove the door catch plate.
- 5) Remove glass retainers on sides first (3 each side) then remove two center retainers.

Note: Center glass retainers are glued to center glass.

- 6) Remove glass from aluminium extrusions. When removing center glass, leave white insulation in place.

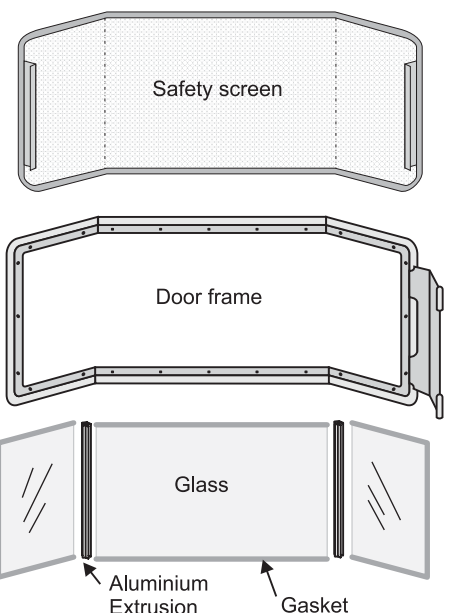

Safety Screen: Only required in Australia

MAINTENANCE

Installing Glass:

- 1) Install both center and side glass onto aluminium extrusions as per diagram.

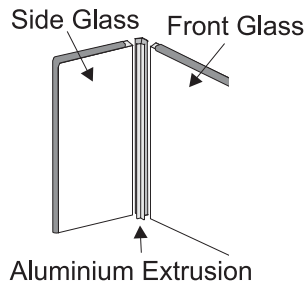

- 2) Place glass assembly into door frame.
- 3) Install retainers by placing 1 drop of glue where previously glued and put in place.
- 4) Install side retainers.
- 5) Install door catch plate.
- 6) Install the 24 nuts loosely, do not tighten yet.
- 7) Tighten side panels nuts using the following procedure:
 - a. tighten top & bottom outside corner nuts (2)
 - b. tighten inside nuts (3)
 - c. tighten top & bottom inside corners (2)
- 8) Tighten the 10 nuts on center glass retainer.
- 9) Repeat step 7 for other side panel.
- 10) Replace new gasket by gluing it in place.
- 11) Install door onto stove and check the seal.

IMPORTANT
Disconnect power supply
before servicing

IMPORTANT: These fans collect a lot of dust from within your home. Ensure you maintain these fan motors on a regular basis by vacuuming out the fan squirrel cages, around the motor, and around the grills on the back of the stove.

WARNING: Electrical Grounding Instructions This appliance is equipped with a three pronged (grounding) plug for your protection against shock hazard and should be plugged directly into a properly grounded three-prong receptacle. Do not cut or remove the grounding prong from this plug.

To Remove F38-1 Fan:

- 1) Unplug or disconnect power source to stove.
- 2) Remove all logs and the rear log support, then remove the 10 screws holding the access panel in place, see Diagram 1. (Fan is also accessible by opening the right side door. See Diagram 2).
- 3) Unclip the black and white wires from the fan motor.

- 4) Lift fan off of the 2 pins, tip back and pull through firebox opening. Disconnect the green ground wire from the left side of the fan as soon as you can reach it.

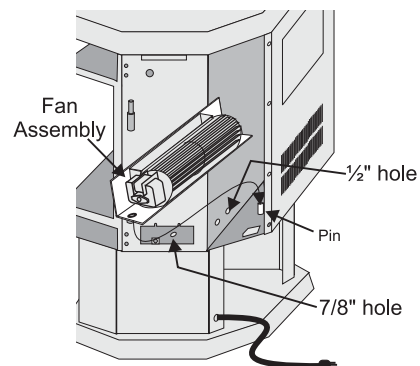

Diagram 2

Replacing F38-1 Fan:

Reverse the above steps (1 - 4). If necessary install a new gasket before replacing the fan access panel. Make sure the fan wires and the ground wire are reattached.

FAN MAINTENANCE

If your fan requires maintenance or replacement, access to the fan is through the access panel on the rear wall of the firebox.

If the unit is damaged or needs repair, it shall be repaired by the manufacturer or its service agent or similarly qualified person in order to avoid a hazard.

Note: The unit **MUST NOT** be operated without the fan access panel securely in place and correctly sealed.

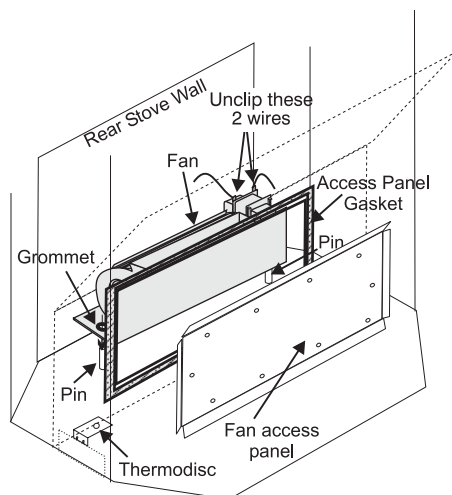

Diagram 1

REMOVING VALVE

If your valve requires maintenance or replacement, follow these instructions:

NOTE: Always shut off the gas supply before removing the valve.

- 1) Open front pedestal door and unhook chain. You may want to put a soft cloth on the base of the unit so that when the pedestal door is open it doesn't scratch the paint. See diagram below.

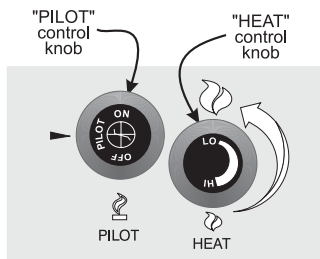
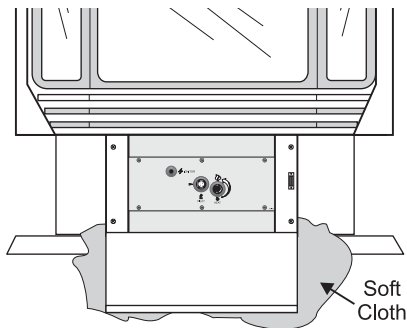

- 2) Undo the six screws holding the control panel in place.
- 3) Disconnect all wires from the back of the panel and then remove panel. You should lay the panel on a soft cloth so it doesn't get marked up. See diagram below.

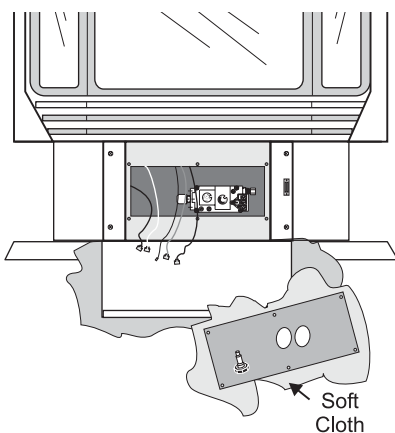

- 4) Remove the two outside frame pieces by removing two screws per side. See diagram below.

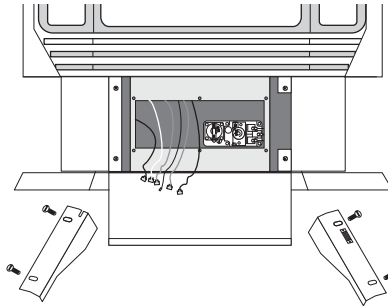

- 5) Carefully remove the logs and lava rock.
- 6) At this point you should disconnect the gas at the valve.
- 7) Remove the burner by removing the two 1/4" hex head screws. See diagram below.

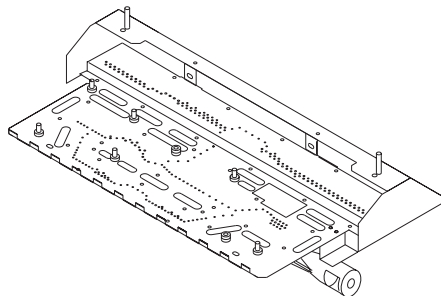

Note: Use a magnetic type screwdriver.

- 8) Remove eight 1/4" hex head screws holding the burner tray assembly in place.

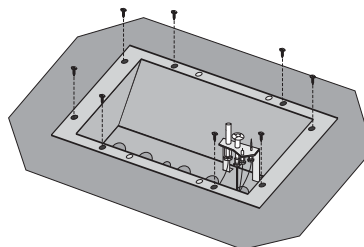

- 9) Carefully lift the burner tray assembly out.

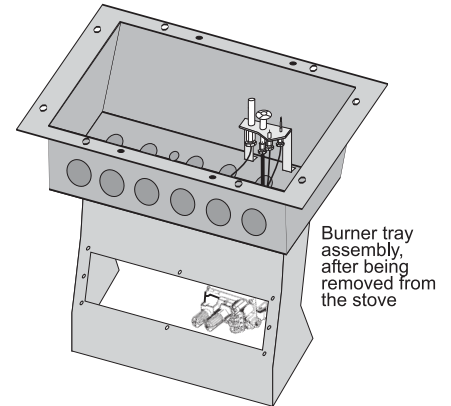

- 10) To replace the burner tray assembly, simply reverse these instructions.

DC Spark Box Battery Replacement

The DC Spark Box can be easily accessed thru the control panel opening of the burner tray assembly.

To replace the battery of the DC Spark Box, simply lift off the battery cover, and replace the old AA Alkaline battery with a new one. Be sure to put the battery cover back in place.

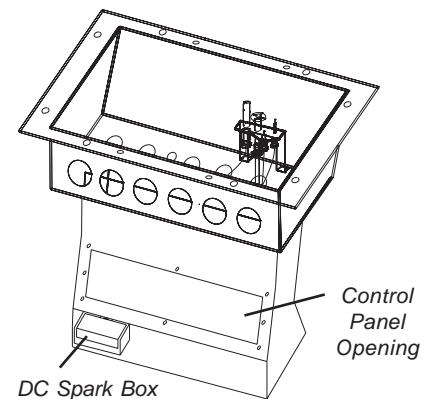

DC Spark Box

PARTS LIST

F38-1 MAIN ASSEMBLY

| Part#: | Aust. | New Zealand | Description | Aust. | New Zealand | Description |
|--------|-----------|-------------|-----------------------------------|---------|-------------|--------------------------------|
| 1) | 560-920 | | Top/Bottom Gold Louvre (Set) | 24) | 948-255 | 556074 Door Latch c/w Hook |
| | 560-922 | | Top/Bottom Black Louvre (Set) | 27) | 910-233 | 560065 Thermodisc - |
| 2) | 750-532 | | Safety Screen (Australia only) | | | Fan Auto On/Off |
| 9) | 560-055 | | Fan Access Door | 28) | * | Mounting Bracket - |
| 10) | 730-034 | | Gasket for Fan Access Door | | | Fan Thermodisc |
| | 560-519 | | Fan Assembly | 29) | * | Thermodisc Cover |
| 11) | 910-167/P | | Fan Motor (240 Volt) | 30) | 750-026 | Rear Panel |
| 12) | 910-714 | | Power Cord (240 Volt) | 32) | 730-018 | Firebox Baffle |
| 15) | * | | Pedestal Assembly | 33) | 560-535 | False Top Assembly |
| 16) | 730-039 | | Pedestal Door | 34) | 590-273 | 560245 Flue Attachment Bracket |
| 17) | 904-257 | 551893 | Pedestal Door Magnet | 35) | 590-930 | Ult. 6" Flue Collar (Optional) |
| 18) | 560-025 | | Pedestal Back | 38) | 820-058 | 556077 Pedestal Base Cover |
| | 910-073 | | Spark Generator Battery Holder | 46) | 750-067 | Rear Control Panel |
| 19) | 756-518 | | Side Panel Door Assy (Right Side) | 680-969 | | Conversion Kit - to LPG |
| 20) | 756-520 | | Side Panel Door Assy (Left Side) | 948-217 | | Logo Plate |
| 21) | 560-031 | 560242 | Hinge for Side Panel | 918-186 | | Manual |
| 23) | 904-258 | 551891 | Side Panel Door Magnet | | | |

*Not available as a replacement part.

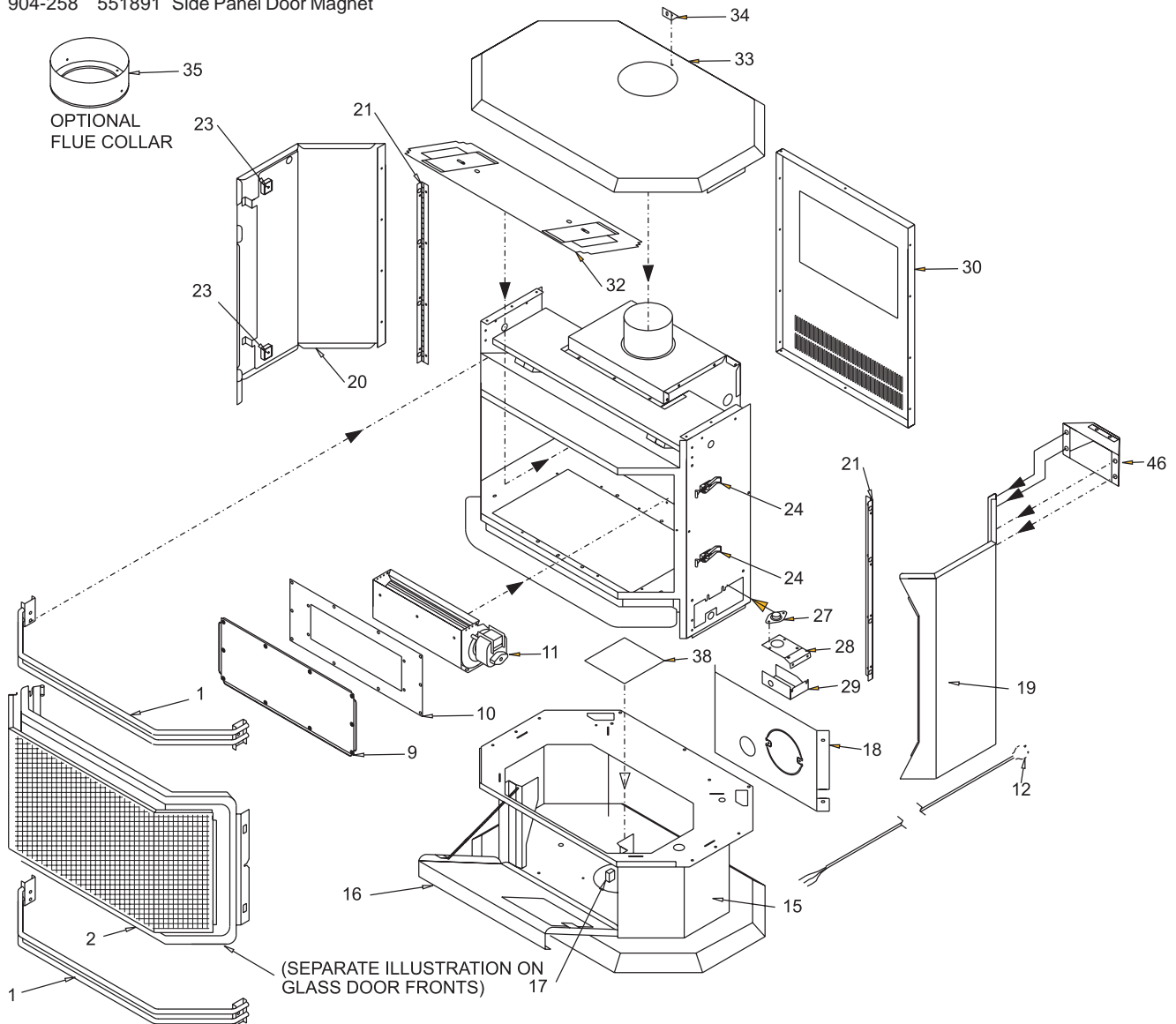

F38-1 BURNER & LOG ASSEMBLY

| Part # | Description |
|-------------|-------------------------------------|
| 54) 910-373 | Knob - S.I.T. Valve Extension |
| 55) 910-372 | Flame Adjusting Knob |
| 56) 918-088 | Control Panel Decal |
| 57) * | Control Panel Plate |
| 752-578/P | Valve Assembly - NG |
| 752-580/P | Valve Assembly - LPG |
| 60) 910-378 | Valve S.I.T. - NG |
| 910-380 | Valve S.I.T. - LPG |
| 904-689 | #33 Orifice - NG at 38 mj. |
| 904-390 | #52 Orifice - LPG at 31 mj. |
| 910-074 | Spark Generator Switch c/w Wire |
| 71) 752-528 | Rear Log Bracket Assy |
| 72) 910-034 | Pilot Assy - S.I.T. - 3 flame - NG |
| 910-035 | Pilot Assy - S.I.T. - 3 flame - LPG |
| 75) 730-935 | Log Set |
| 78) 752-525 | Burner Assy - NG/LPG |
| 90) 910-386 | Thermocouple |
| 91) 910-341 | Thermopile |
| 92) 902-267 | Rear Log |
| 93) 902-231 | Left Top Log |
| 94) 902-232 | Center Log |
| 95) 902-226 | Middle Right Log |
| 96) 902-230 | Middle Left Log |
| 97) 902-229 | Front Right Log |
| 98) 902-228 | Front Left Log |

*Not available as a replacement part.

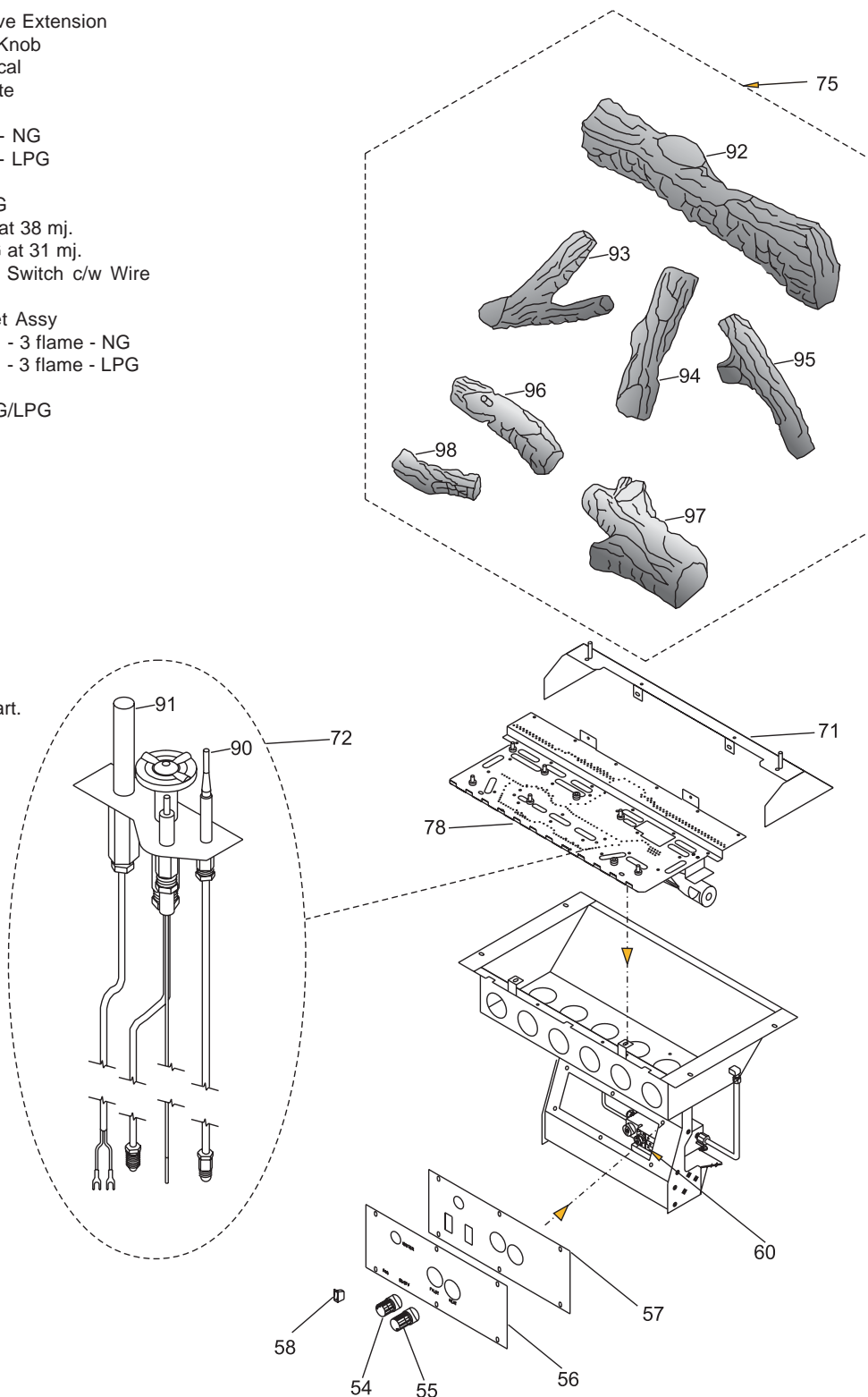

PARTS LIST

F38-1 DOOR ASSEMBLIES

| Part # | Description |
|---------|------------------------------|
| 730-924 | Gold Mitred Door - Complete |
| 730-926 | Black Mitred Door - Complete |
| 730-932 | Gold Wrap Door - Complete |
| 730-928 | Gold Panel Door - Complete |
| 101) | 650-920 Door Gasket Kit |
| 105) | * Ceramic Paper |
| 106) | 940-323/P Side Glass |
| 107) | 936-243 Glass Gasket |
| 108) | 940-322/P Centre Glass |
| 111) | * Door Frame Fibre Paper |
| 112) | 750-015 Door Glass Extrusion |
| 208) | 940-325/P Wrap Glass |

*Not available as a replacement part.

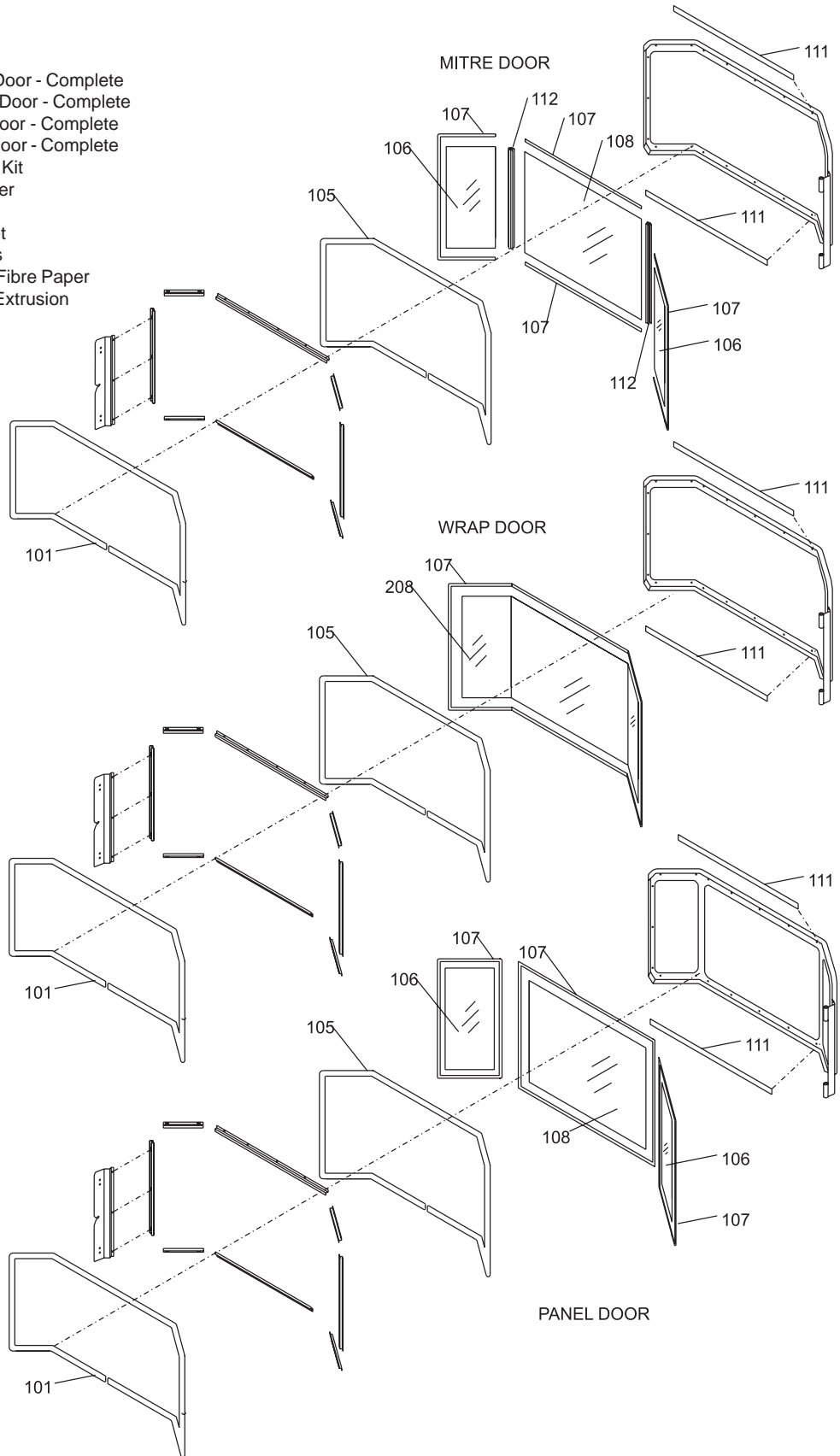

THE MASPORT EXPRESS WARRANTY

All new Masport Gas appliances are warranted, subject to the following conditions, to be free from defects in material or workmanship under normal use. The Express Warranty on all parts, including firebox components but excluding fans, flues and flue accessories is two years from date of original purchase as well as labour costs involved in the repair or replacement. The Express Warranty on fans, flues and accessories is for a period of twelve months from date of original purchase and includes labour costs involved in the repair or replacement.

This Express Warranty applies only with respect to defects in material and workmanship under normal and proper use of the NEW UNIT in its unmodified condition. Masport's obligation under this Express Warranty is limited to the repair or replacement, at its option, by an approved Masport Gas Service Agent (Retailer) of any part found to be defective in material or workmanship.

Labour costs involved in the repair or replacement are also covered under this Express Warranty as per the time condition outlined.

If an approved Masport Gas Service Agent is requested to attend on a service call that is not covered under this Express Warranty, a call out charge may be applicable, regardless of whether a repair is carried out or not.

Masport can accept no obligation whatsoever for any incidental, consequential or special damages or expenses resulting from any product defect. This Express Warranty applies from the date of original purchase, applies to the original purchaser, and is not transferable. The decision to repair or replace defective components will be made by Masport or its agent and actioned by an approved Masport Service Agent.

This Express Warranty Does Not Cover:

1. Defects, malfunctions or failures caused by incorrect installation, normal wear and tear, misuse, neglect, accidental damage or failure to follow the fuel selection, product operating and maintenance instructions, or resulting from installations, repairs or modifications to the equipment carried out by unauthorised persons.
2. Defects, malfunctions or failures caused by an act or omission of other persons after the product has left Masport's control.
3. The costs of collection and delivery of the equipment.
4. The cost of labour or materials as a consequence of faulty installation of gas supply line, flue, burner or log settings, or non-compliance with local codes.

The Express Warranty is not intended to exclude any rights the purchaser may have under the laws of the place, state, or country of purchase. Nothing in this Express Warranty limits or restricts any other statutory right or remedy available to the purchaser.

How You Obtain Warranty Service:

Provide proof of the date of purchase. Should the need for a warranty claim arise reasonable proof of the purchase date is required therefore you should retain your sales receipt. Where flueless appliances are not permanently installed, they should be returned to a Service Agent for evaluation.

Make the faulty part(s) available for inspection by Masport and/or its agents so that the validity of the claim can be established by them.

Australia Distributor:

Masport Pty Limited
P.O. Box 533
Braeside Victoria 3195

New Zealand:

Masport Limited
P.O. Box 14-349
Panmure
Auckland 6

For your own records, please complete the following:

| | |
|----------------------|----------------------|
| Model: _____ | Serial Number: _____ |
| Retailer: _____ | |
| _____ | |
| Purchase Date: _____ | |

